

WIRE CONTROLLER INSTALLATION MANUAL



MODEL: KJR-12B/DP(T)-E
KJR-12B/DP(T)-E(C)
KJR-12B/DP(T)-F

Version: MDV06I-002EW
202000100067

Thank you very much for purchasing our product.
Before using your unit, please read this manual carefully and keep it for future reference.

SAFETY PRECAUTION

- Read the safety precautions carefully before installing the unit.
- Stated below are important safety issues that must be obeyed.
- Conform there is no abnormal phenomena during test operation after complete, then hand the manual to the user.
- Meaning of marks:

	WARNING	Means improper handling may lead to personal death or severe injury.
	CAUTION	Means improper handling may lead to personal injury or property loss.



WARNING

Please entrust the distributor or professionals to install the unit.
Installation by other persons may lead to imperfect installation, electric shock or fire.

Strictly follow this manual.
Improper installation may lead to electric shock or fire.

Reinstallation must be performed by professionals.
Improper installation may lead to electric shock or fire.

Do not disassemble your air conditioner at will.
A random disassembly may cause abnormal operation or heating, which may result in fire.



CAUTION

Do not install the unit in a place vulnerable to leakage of flammable gases.
Once flammable gases are leaked and left around the wire controller, fire may occur.

The wiring should adapt to the wire controller current.
Otherwise, electric leakage or heating may occur and result in fire.

The specified cables shall be applied in the wiring. No external force may be applied to the terminal.
Otherwise, wire cut and heating may occur and result in fire.

OTHER PRECAUTIONS

Installation Location

Do not install the unit in a place with much oil, steam, sulfide gas. Otherwise, the product may deform and fail.

Preparation before installation

1. Check whether the following assemblies are complete.

No.	Name	Qty.	Remarks
1	Wire controller	1	
2	Wood Mounting Screw	3	GB950-86 M4X20 (For Mounting on the Wall)
3	Mounting Screw	3	GB823-88 M4X25 (For Mounting on the Electrical Switch Box)
4	Installation Manual	1	
5	Owner's Manual	1	
6	5-terminal Group	1	RS9005E
7	Terminal Installation Screw	2	ST3.9x12-F-H GB845-85

2. Prepare the following assemblies on the site.

No.	Name	Qty.	Type	Remarks
1	5-core shielded cable	1	RVVP-0.5mm ² x5	The longest wire is 15m
2	Switch box	1		
3	Wiring Tube(Insulating Sleeve and Tightening Screw)	1		

Note to installation of wire controller:

1. This manual contains information about the procedure of installing wire controller. Please refer to Indoor Unit Installation Manual for connecting between Wire Controller and Indoor Unit.
2. Install the Wire joint,5p to the appointed position of the electric controlling Box.
3. Circuit of Wire Controller is low voltage circuit, Never connect it with a standard 220V/380V circuit or put it into a same Wiring Tube with the circuit, and the interval must be more than 300~500mm.
4. The shield cable must be connected stable to the ground, or transmission may fail.
5. Do not to attempt to extend the shield cable by cutting, if it is necessary, use Terminal Connection Block to connect.
6. After finishing connection, do not use Megger to have the installation check to the signal wire.

INSTALLATION PROCEDURE

Wiring technique and principle:

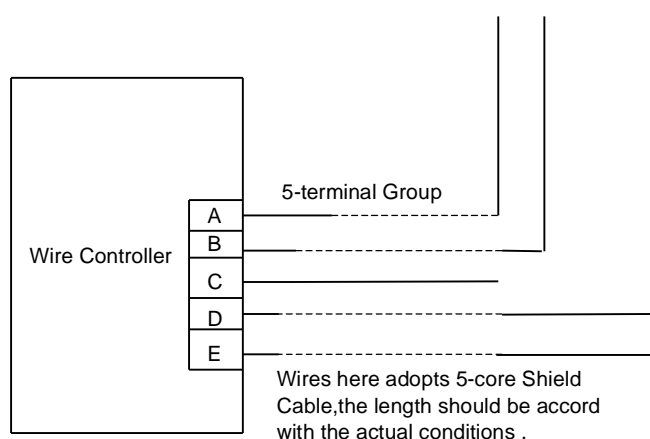

Installation description:

When it is necessary to use this controller, it needs to add a small 5-terminal Group and fasten an infrared emitter near to the receiver in the switch board. Connecting the anode and cathode to A、B of the Terminal Group, also connect +5V、GND、RUN of the switch board separately to the C、D、E of the 5-terminal Group.

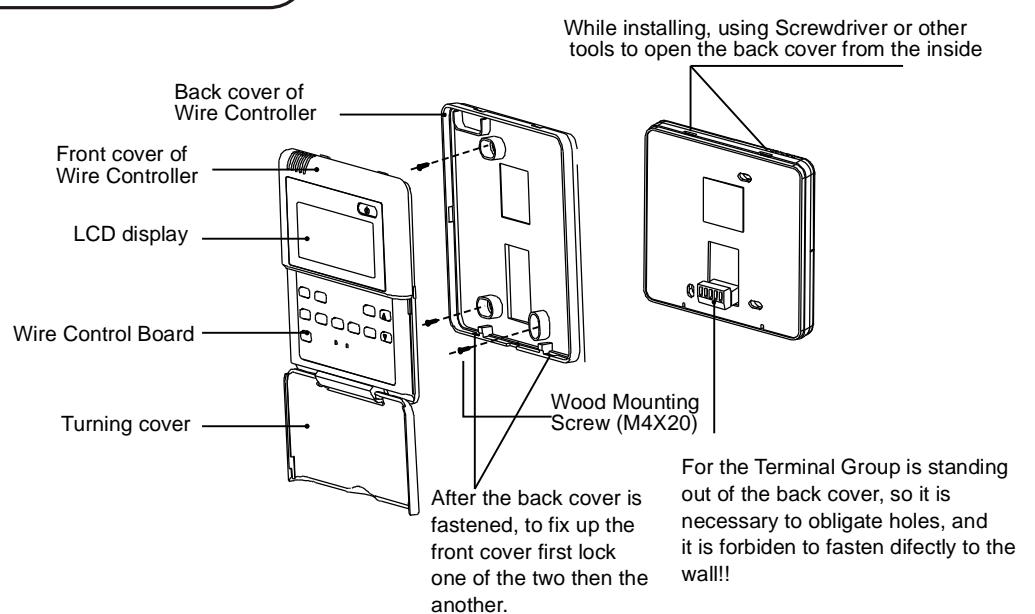

CAUTION

- The connecting wire should be a little longer as to take away the switch board easily for maintenance
- The connecting wire should be a little longer as to take away the controller easily for maintenance..

1. Wiring diagram between wire controller and four-way cassette of indoor unit

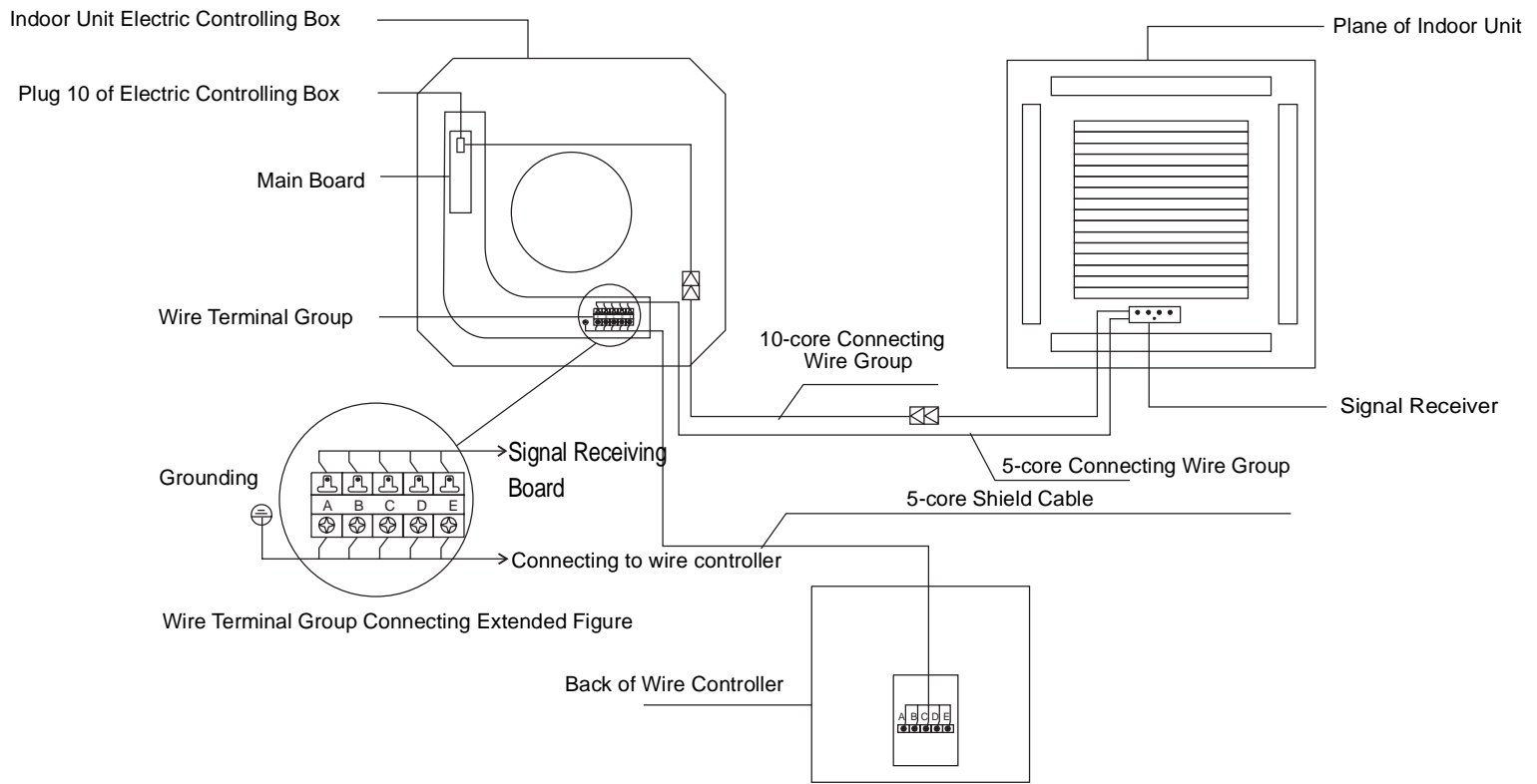

2. Wiring diagram between wire controller and duct type of indoor unit

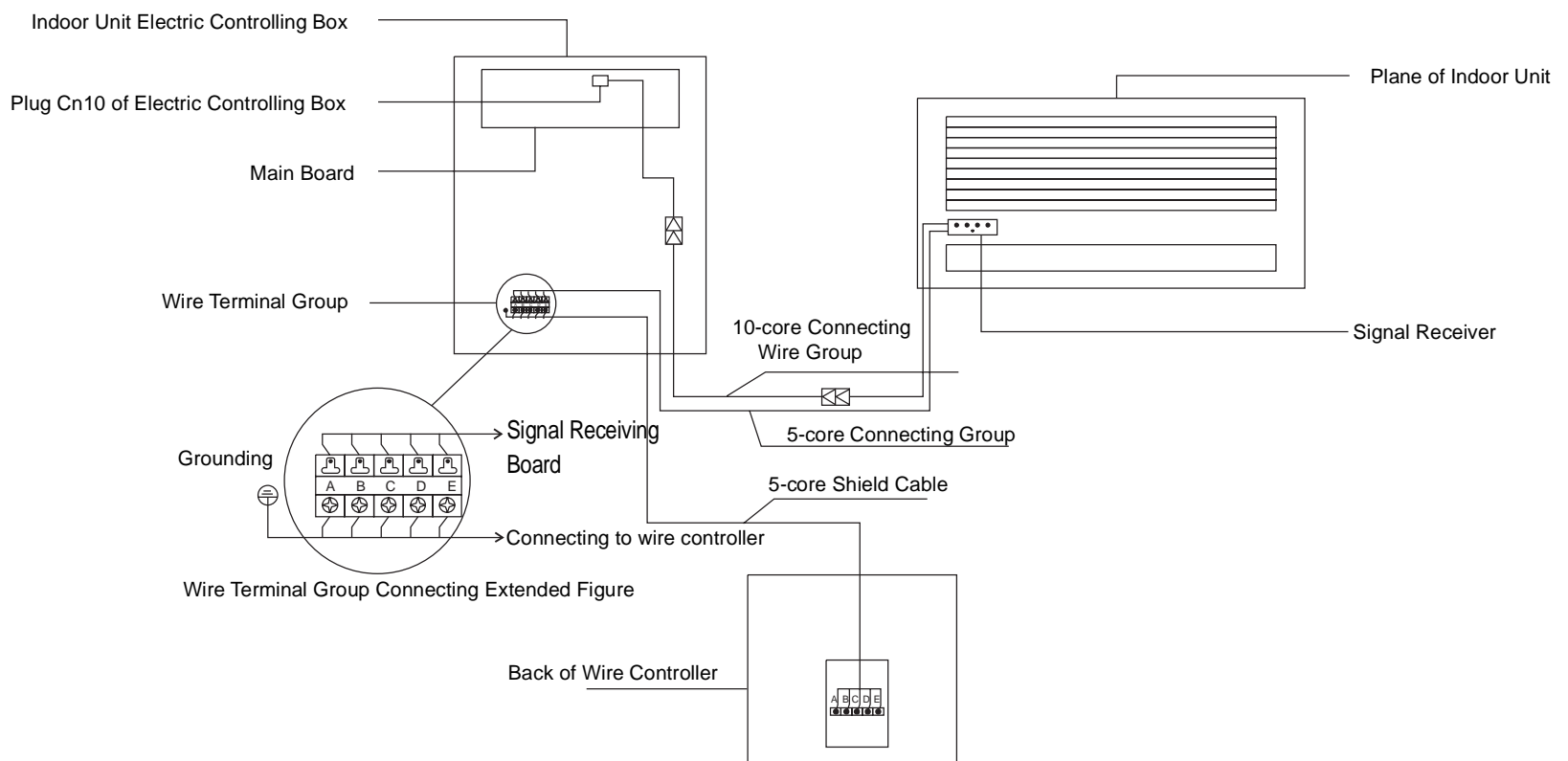

3. Wiring diagram between wire controller and high static duct type of indoor unit

